

MURZAN

ABDT Juice Concentrate Unloading System

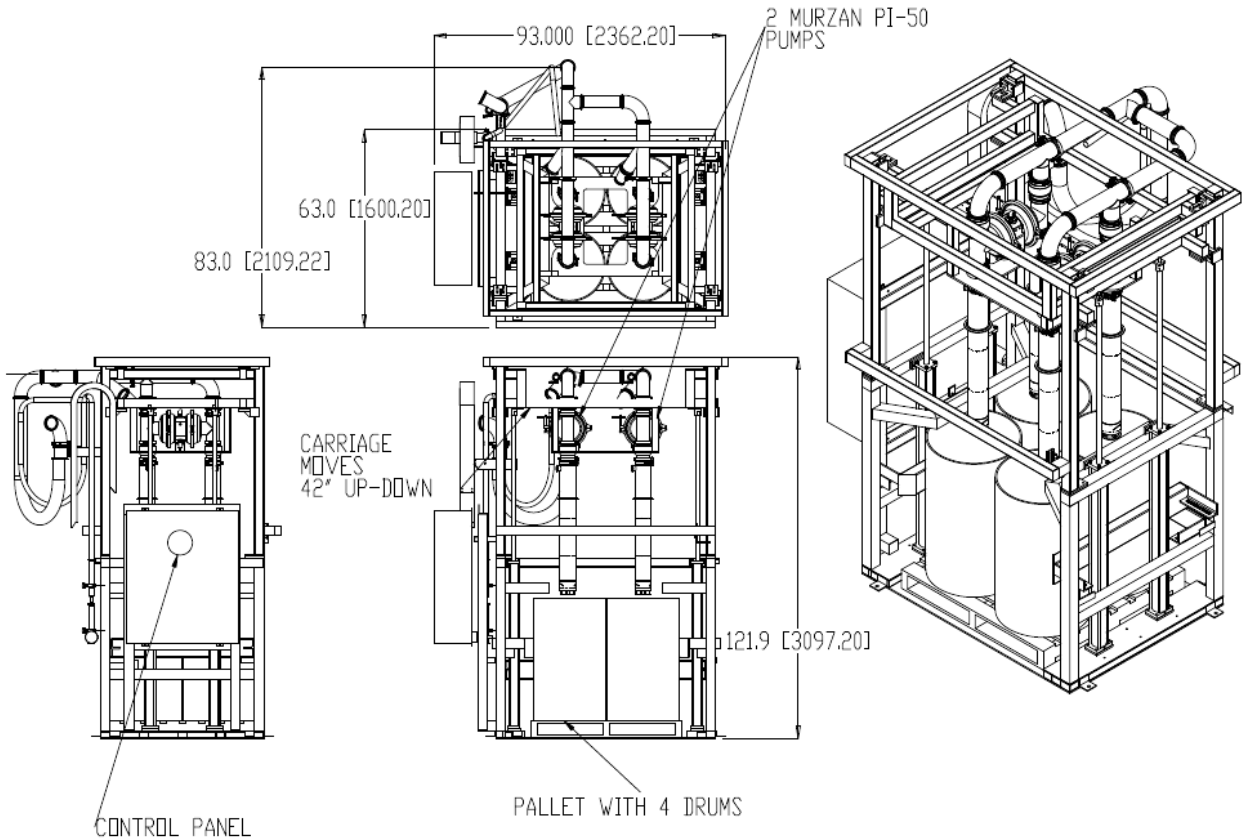

THE MURZAN ABDT JUICE CONCENTRATE UNLOADING SYSTEM
USDA APPROVED TECHNOLOGY THAT WILL
UNLOAD YOUR PRODUCT WITH NO WASTE OF CONCENTRATE



The Murzan ABDT juice concentrate unloading system consists of two double diaphragm pumps that are mounted on a stainless steel carriage that moves the pumps and suction wand up and down to allow entrance and unloading of the four drums on a pallet at the same time.

The ABDT is equipped with a wash down bag system that will allow you to rinse the residues inside the bag in order to obtain maximum yield.

ABDT also has a mechanism that will lift the bags inside the drums to collect the maximum of your product contained inside the bag.