



Powerprime



Powerprime sanitary model. Polished stainless steel

For semi-flowable & sticky products

The transfer of viscous and sticky products from drums or process containers can be a problem as they do not flow easily into the suction inlet of the pump and also tend to stick to the sides of the drum.

Kecol's 'Powerprime' single column pressure priming system, used in conjunction with a Kecol piston pump, overcomes these problems by providing a constant pressure on the surface of the product in the drum, which 'force feeds' the pump. As the level of the product drops, a follower plate maintains the pressure on the surface of the product and at the same time wipes the sides of the drum.

Features & Benefits

Ideal for viscous & sticky products

Eliminates Product Waste

Prevents Product Contamination

Simple and Safe to Operate

Polished Stainless Steel or Painted Steel Construction

Typical Applications

Food

Brandy butter, whipped butter & butter mixes
 orange & fruit concentrates, tomato puree, ie
 pie fillings, beer mustard, cooking fats, etc

Pharmaceutical & Cosmetics

Ointments, creams, mascara, face scrub, etc

Chemical & General Industrial

Adhesives, phenolic resin, plasticizer,
 printing inks, sealants, paints, tile adhesive

Operation

Compressed air entering the air cylinder transmits a downward force on the follower plate, which in turn pressurises the material in the drum/container causing material to be forced into the suction chamber of the pump. The extra pressure created by the Powerprime unit increases the flow of material to the inlet to the pump resulting in a much improved output. During the pumping cycle the level of the product gradually falls and the wiper blade on the follower plate wipes the sides of the vessel. Once the drum or container is empty the direction of the air cylinder is reversed lifting the pump and follower plate clear ready for changing the drum/container.

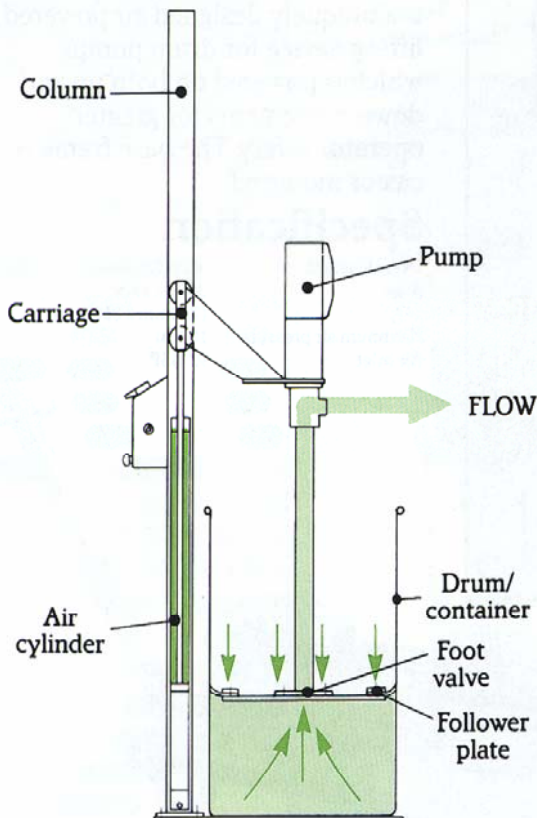

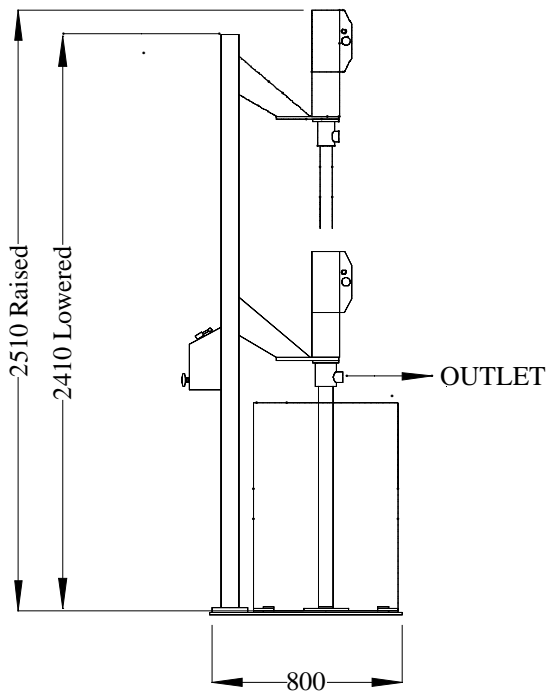

1/2" BSP (F)
AIR CONNECTION

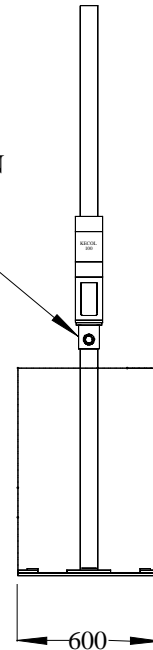

Articulated Powerprime sanitary model.

Articulated Powerprime

This innovative development from Kecol enables up to four open top drums to be emptied, one at a time, whilst loaded on a pallet. A Kecol drum pump, with follower plate attached, is fixed to the arm of the Articulated Powerprime system. The pump and follower plate are raised and positioned centrally over one of the open top drums on the pallet, then lowered until making contact with the product in the drum. Once the pump is started, the Articulated Powerprime operates in exactly the same way as the standard Powerprime system.



Measuring Cylinder

Measuring Cylinders

Used in conjunction with a Kecol Piston Pump Pressure Priming System these Measuring Cylinders will dispense a predetermined volume of liquid or viscous product. They are constructed of either carbon steel or 316 stainless steel and are available in either manual or pneumatic actuation and fixed or adjustable outputs from about 200ml up to 3 Litres. Accuracy is normally better than $\pm 1\%$.



Megaprime system

Maxiprime & Megaprime Systems

The Maxiprime & Megaprime twin cylinder pressure priming systems provide increased pressures for handling pastes up to 10,000 poise viscosity. Standard & non-standard drums & containers up to about 1.2 metre diameter can be used.



Special System

Non-Standard Pumps & Systems

Whether your requirement is for a special length piston pump with a non-standard outlet fitting or a Powerlift, Powerprime or Maxiprime system for non-standard vessels, Kecol will design and manufacture a unit to suit your requirements.

Our engineers will be pleased to discuss the many different options that are available such as interlocking guards, jacking or standard castors, drum loading systems, quick strip pumps, dispensing and filling systems, etc.